



INDUSTRIAS METALURGICAS CESTARI S.R.L.

ST SERIES

EQUIPAMIENTO

Llantas DW 20x30

Neumáticos: 23.1-30 R1 y R3

EQUIPMENT

Rims: DW 20x30

Tires: 23.1-30 R1 and R3



14.800 L

ESPECIFICACIONES TÉCNICAS
TECHNICAL SPECIFICATIONS

Peso Tara	Weight Tare:	2.400 kg. (*1)
Capacidad	Capacity:	14.800 Lts. (*2)
Carga máxima	Maximum load:	13.000 Kg.
Ø tubo	Ø Tube:	420 mm.
Ø sinfín de piso	Ø Floor auger:	336 mm.
Ø sinfín de tubo	Ø Tube auger:	396 mm.
Tiempo de descarga	Unloading time:	2 min. (*3)

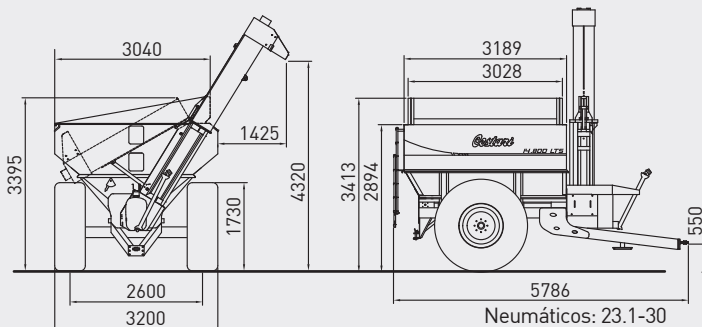

ST SERIES

ESPECIFICACIONES TÉCNICAS

Doble chasis / Estructura abulonada / Horquillas reforzadas (4R) / Masas de acero forjado / Puntas de eje: desmontables, templadas y bonificadas / Sistema de lanza fija / Sistema hidráulico de accionamiento del fondo deslizante (sistema de limpieza y descarga por gravedad) / Tubo inferior de descarga desmontable (tipo camisa).

EQUIPAMIENTO ESTÁNDAR

Escaleras normalizadas / Gato mecánico elevación (2R) / Indicador de apertura de compuertas de piso / Indicadores de ajuste del neumático / Llantas enteras: soldadas por fuera y dentro / Luces traseras fijas / Organizador de mangueras / Paragolpes trasero deslizante / Pintura poliuretánica / Sinfines con refuerzo doble espesor en los extremos y pernos desmontables abulonados.

OPCIONAL

Balanza / Cajón de herramientas / Gato hidráulico de elevación (2R). / Luces traseras rebatibles / Neumáticos a elección / Pintura base agua y epoxi fenólico / Sinfines con recargue duro en su totalidad o en sus extremos (cementados) / Sistema de cobertura con lona enrollable / Sistema de lubricación externa centralizada.

EQUIPAMIENTO

Llantas: DW 20x30, DW 21x32
y DW 27x 32 (M.B. 8 agujeros)
Neumáticos: 23.1-30 R1
y R3, 24.5-32 R1 y R3, 30.5L-32

EQUIPMENT

Rims: DW 20x30, DW 21x32
y DW 27x 32 (M.B. 8 holes)
Tires: 23.1-30 R1
y R3, 24.5-32 R1 y R3, 30.5L-32



ST SERIES

TECHNICAL SPECIFICATIONS

Bolted structure / Bottom sliding floor driving by hydraulic system (cleaning system and gravity download) / Detachable and induction hardened spindles / Dual chassis / Forged hubs wheel / Reinforced Steering forks (4W) / Removable lower unloading tube (extension casing) / Welded towbar system (fixed).

STANDARD EQUIPMENT

Closed rims, welded inside and outside / Fixed rear lights / Floor hatches opening indicator / Hydraulic hoses organizer / Mechanical Lifting Jack (2W) / Polyurethane Painting / Reinforced augers with double thickness in the ends and detachable bolts / Sliding rear bumper / Standard Ladders: rear hinged and internal / Wheel adjustment indicators.

OPTIONAL

Centralised lubrication system / Hardfacing augers in whole or in its ends / Hinged rear lights / Hydraulic lifting Jack (2W) / Plastic Toolbox / Roll Top canvas system / Scale / Tyres / Water-based and epoxy phenolic painting.

ESPECIFICACIONES TECNICAS
TECHNICAL SPECIFICATIONS

20.000 L

Peso Tara	Weight Tare:	2.900 kg. (*1)
Capacidad	Capacity:	20.000 Lts. (*2)
Carga máxima	Maximum load:	16.000 Kg.
Ø tubo	Ø Tube:	420 mm.
Ø sinfín de piso	Ø Floor auger:	336 mm.
Ø sinfín de tubo	Ø Tube auger:	396 mm.
Tiempo de descarga	Unloading time:	2,5 min. (*3)

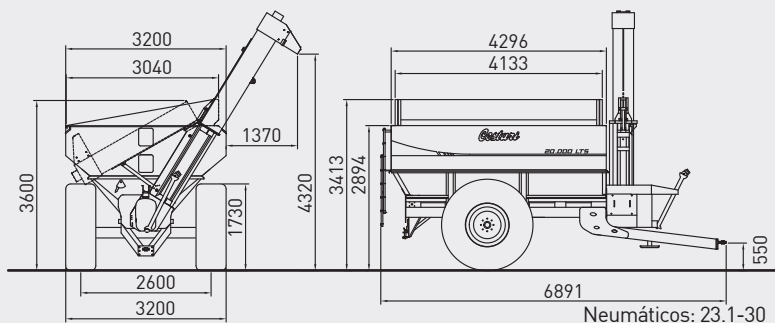

- [*1] CON LLANTAS SIN NEUMÁTICOS
WITH RIMS, WITHOUT TIRES.
- [*2] SIN REBASE SUPERIOR
NOT EXCEED THE UPPER EDGE.
- [*3] CEREAL SECO A 540 R.P.M.
DRY CEREAL AT 540 RPM.



ESPECIFICACIONES TECNICAS
TECHNICAL SPECIFICATIONS

24.000 L

Peso Tara	Weight Tare:	3.830 kg. [*1]
Capacidad	Capacity:	24.000 Lts. [*2]
Carga máxima	Maximum load:	21.000 Kg.
Ø tubo	Ø Tube:	420 mm.
Ø sinfín de piso	Ø Floor auger:	336 mm.
Ø sinfín de tubo	Ø Tube auger:	396 mm.
Tiempo de descarga	Unloading time:	3 min. [*3]

EQUIPAMIENTO

Llantas: DW 27x32 (M.B. 10 agujeros)
Neumáticos: 30.5L-32, 30.5 LR-32 y 800/65 R-32

EQUIPMENT

Rims: 27x32 (M.B. 10 holes)
Tires: 30.5L-32, 30.5 LR-32 and 800/65 R-32

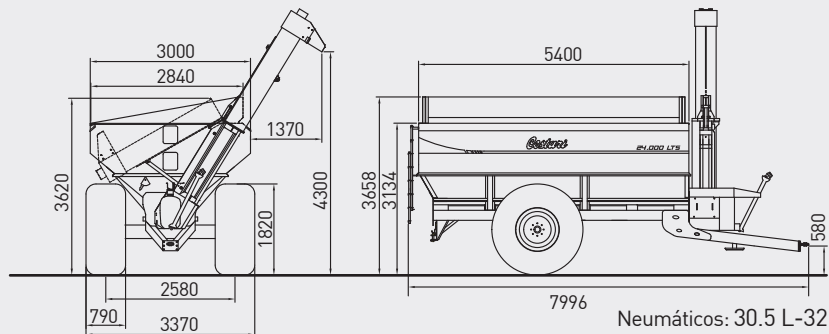

Fotos ilustrativas. Modelos sujetos a cambios.
Illustrative photos. Models are subject to change.



ESPECIFICACIONES TECNICAS
TECHNICAL SPECIFICATIONS

24.000 L 4R

Peso Tara	Weight Tare:	4.180 kg. (*1)
Capacidad	Capacity:	24.000 Lts. (*2)
Carga máxima	Maximum load:	21.000 Kg.
Ø tubo	Ø Tube:	420 mm.
Ø sinfín de piso	Ø Floor auger:	336 mm.
Ø sinfín de tubo	Ø Tube auger:	396 mm.
Tiempo de descarga	Unloading time:	3 min. (*3)

EQUIPAMIENTO

Llantas: DW 20x30 (M.B. 8 agujeros)
Neumáticos: 23.1-30 R3

EQUIPMENT

Rims: 27x32 (M.B. 10 holes)
Tires: 23.1-30 R3

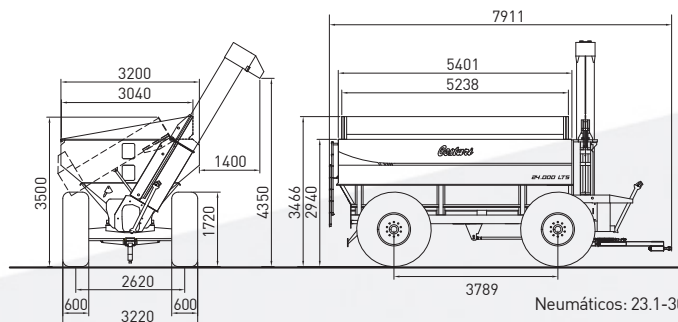

ST SERIES



Más de 90 años liderando el sistema de cosecha.
More than 90 years leading the harvesting system.



 CestariTolvas  cestari tolvas  @CestariTolvas
 cestaritolvas  imcestari.com  00 54 2473 430490
 informes@imcestari.com

Av. Eva Perón 1068, Colón, Buenos Aires, Argentina



MANAGEMENT SYSTEM
ISO 9001:2015
ID 9105049530
WWW.TUV.COM



SEGURIDAD EN
MAQUINARIA AGRICOLA /
SAFETY IN AGRICULTURAL
MACHINERY
IRAM: 8076-0: 2011